

Photoelectric Sensor
BLE 18KW-PA-1LT-C-02
Sn=50000mm
through-beam, receiver

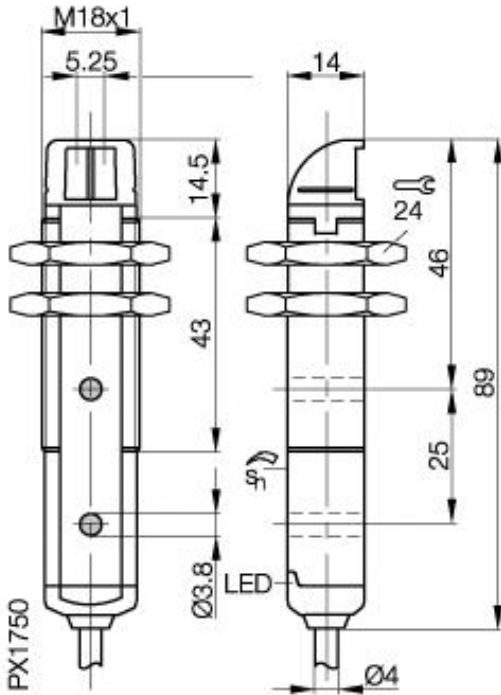

Common Data

Series	18K
Sensortype	through-beam, receiver
Switching frequency	1500 Hz
Rated operating distance Sn in mm	50000
asured operating distance Sa	0...50000
Indication Supply Voltage	yes, green LED
Indication Switching element on	yes, yellow LED
Ambient temperature	-10...+50°C
On-delay	0,33ms
Off-delay	< 0,8ms
Light	Laser, red
Wavelength / Laser protection class	650nm, Protection class 1
Sensitivity Adjustment	Poti 270°
Output function	light-on or dark-on

Mechanical Data

Measurements	M18x89
Shock	Halfsinus, 30gn, 11ms
Vibration	10...55Hz, 1,5mm Amplitude 3x2h
Housing material	PBT
Material of sensing face	PMMA
Degree of protection	IP67
Connection	Cable
Weigth	75g
Type of Cable	PVC, 4x0,14mm ²

Electrical Data

Current	DC
Switching function	NO/NC
Output	PNP
Rated operational voltage Ue	24V DC
Rated operational current Ie	100mA
Supply Voltage	10...30V DC
Ripple	< 10% from UB
Frequency of Supply Voltage	DC
No-load supply current	<30mA
Voltage drop	<2V
Short protection	yes
Protected against polarity reversal	yes

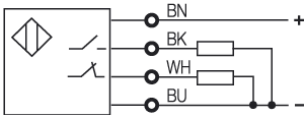

Utilization categories
 Insulation class

DC13

Datasheet number:

Definitions see general catalog.
 If not otherwise noted, ratings according to
 IEC 60947-5-2 (DIN EN60947-5-2)

Balluff GmbH
 Schurwaldstrasse 9
 73765 Neuhausen a.d.F.
 Phone (07158) 173-0 Fax (07158) 5010

Datenblatt by CD-ROM - 04/2007

